



EAR-727HB-RAY

Quick Installation and Programming Guide

Boxed Controller

Alternative to AR-716E-RAY

(This controller operates exactly as the AR-716E-RAY
but utilises a different cabinet and power supply.)

15th October

Version 1.05

Raytel Security  **Systems Limited**

Southern Office:
Raytel House
Brook Road
Rayleigh
Essex,
SS6 7XH
Tel: (01268) 749310
Fax: (01268) 749315

Northern Office:
Unit 3 Block 5
Oakbank Industrial Estate
Garscube Road
Glasgow
G20 7LU.
Tel: (0141) 3324232
Fax: (0141) 3326952

CONTENTS

Topic	Page
Contents	2
Connections	3
Connector Charts	3
Magnetic Lock	4
Solenoid Bolt	5
Fail Safe Release.....	6
Fail Secure Release.....	7
Clean Contacts	8
Programming	9
Programming Menu Tree.....	9
Entering and Exiting Programming mode	10
Initial Setup.....	10
Restoring Factory Settings.....	10
Extremely Important Memory Location Information.....	11
Changing the Master Code	12
Turning off Time and Attendance	12
Setting the Date and Time	13
Setting up the Readers	14
Scan Readers.....	15
Adding a Single Token Using the Token ID	16
Adding a Single Token Using RF Learn	17
Adding a Batch of Tokens Using RF Learn (Sequential Token Numbers).....	18
Adding a Batch of Tokens Using RF Learn (Random Token Numbers)	19
Deleting A Single Token Using the Token ID	20
Deleting A Single Token Using the Memory Location.....	21
Deleting a Batch of Tokens Using the Memory Location Only.....	22
Adjusting the Lock Activation Time	23
Setting Latch Mode.....	24
Enabling and Setting Automatic Door Opening Times.....	25
Anti-passback	27
Resetting Master Code	29
Updating Firmware	30
Token Record Sheet	31

CONNECTOR CHARTS

TB1 Host Connections		
Networking To Host	A+	RS-485 To Host
	B-	
Power Vin	V+	DC Power 12-24V
Power GND	0V	DC Power GND
TB2 Reader 1 Connections		
Power 12VDC	+V	Power To Reader
Power GND	0V	GND To Reader
Relay 1	C/-	Common Relay Output 24V/1A
	NC/+	Normally Closed Relay Output 24V/1A
	NO/+	Normally Open Relay Output 24V/1A
Exit Switch 1	PB1	Negative Trigger Input
Networking To Reader	A+	RS-485 To Reader
	B-	
TB3 Reader 2 Connections		
Networking To Reader	A+	RS-485 To Reader
	B-	
Exit Switch 2	PB2	Negative Trigger Input
Relay 1	C/-	Common Relay Output 24V/1A
	NC/+	Normally Closed Relay Output 24V/1A
	NO/+	Normally Open Relay Output 24V/1A
Power 12VDC	+V	Power To Reader
Power GND	0V	GND To Reader

Proximity Reader Dipswitch Settings for RS485 protocol

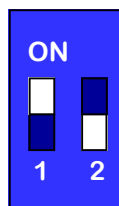

Switch 1 - ON (up) Switch 2 - Off (down)

CONNECTIONS FOR CONTROLLER WITH TWO MAGNETIC LOCKS

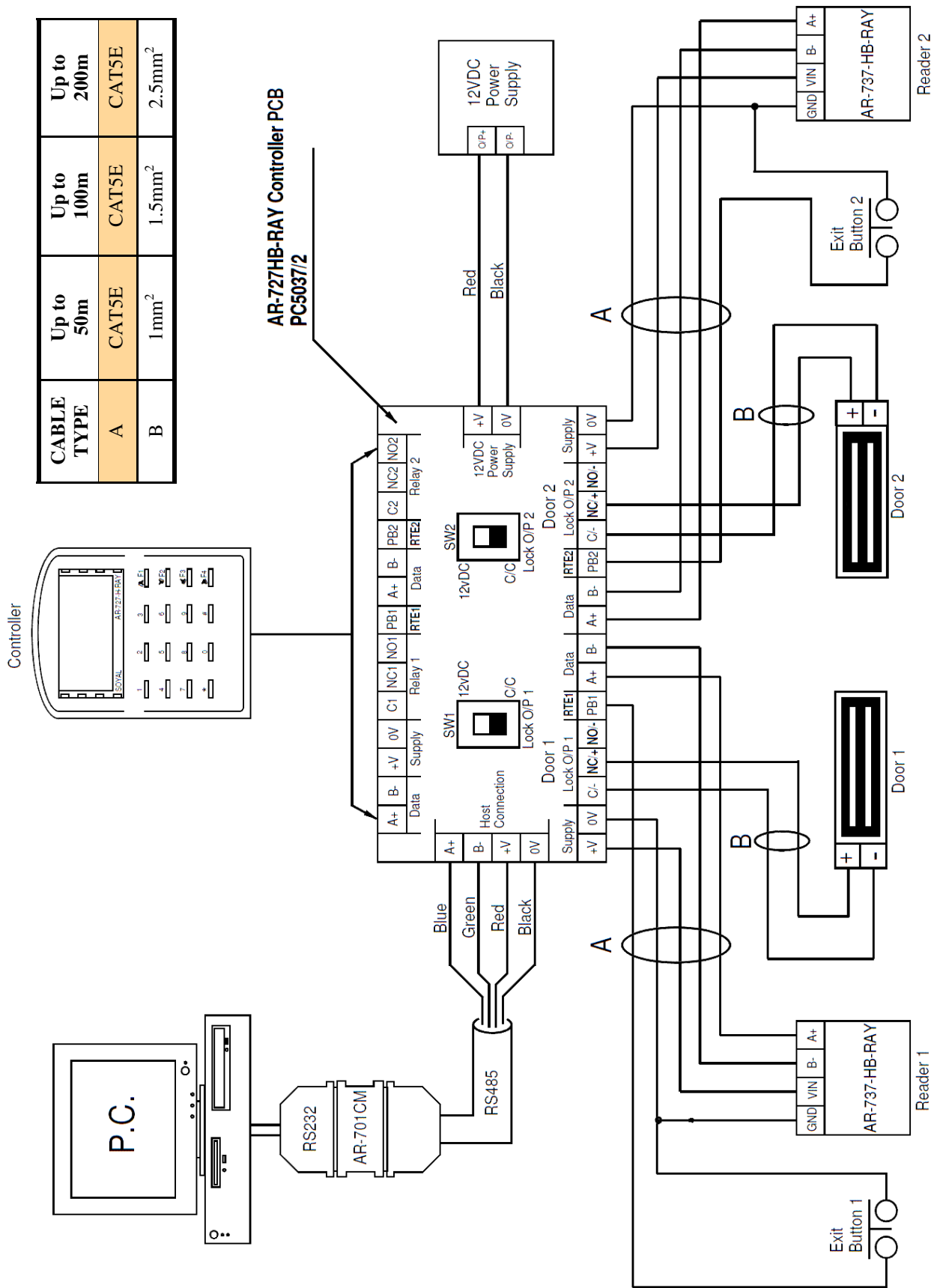

CONNECTIONS FOR CONTROLLER WITH TWO SOLENOID BOLTS

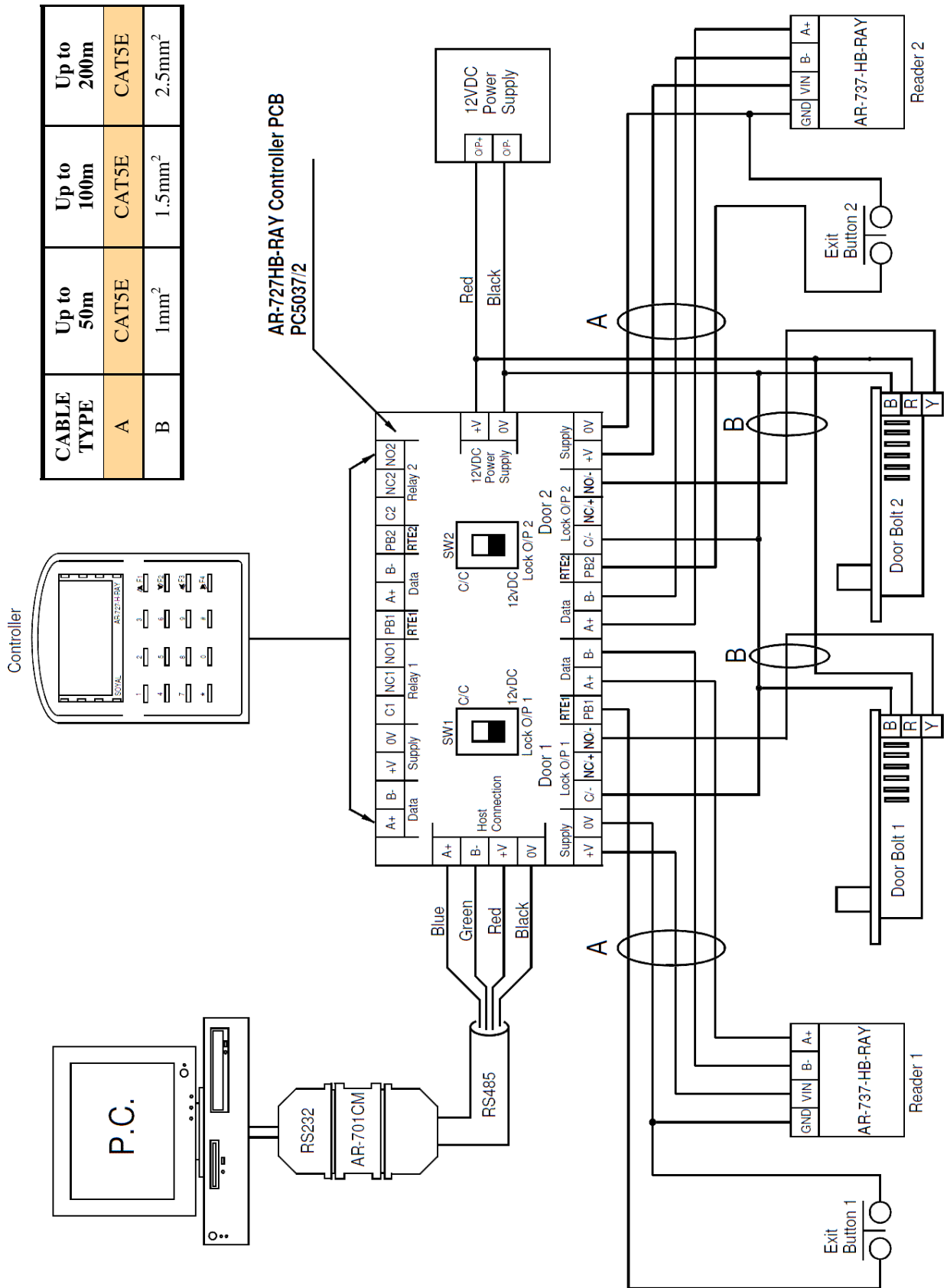

CABLE TYPE	Up to 50m	Up to 100m	Up to 200m
A	CAT5E	CAT5E	CAT5E
B	1mm ²	1.5mm ²	2.5mm ²

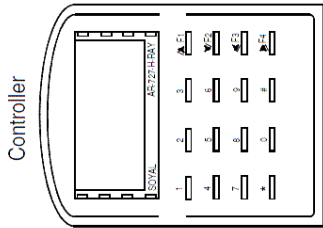

CONNECTIONS FOR CONTROLLER WITH TWO FAIL SAFE RELEASES

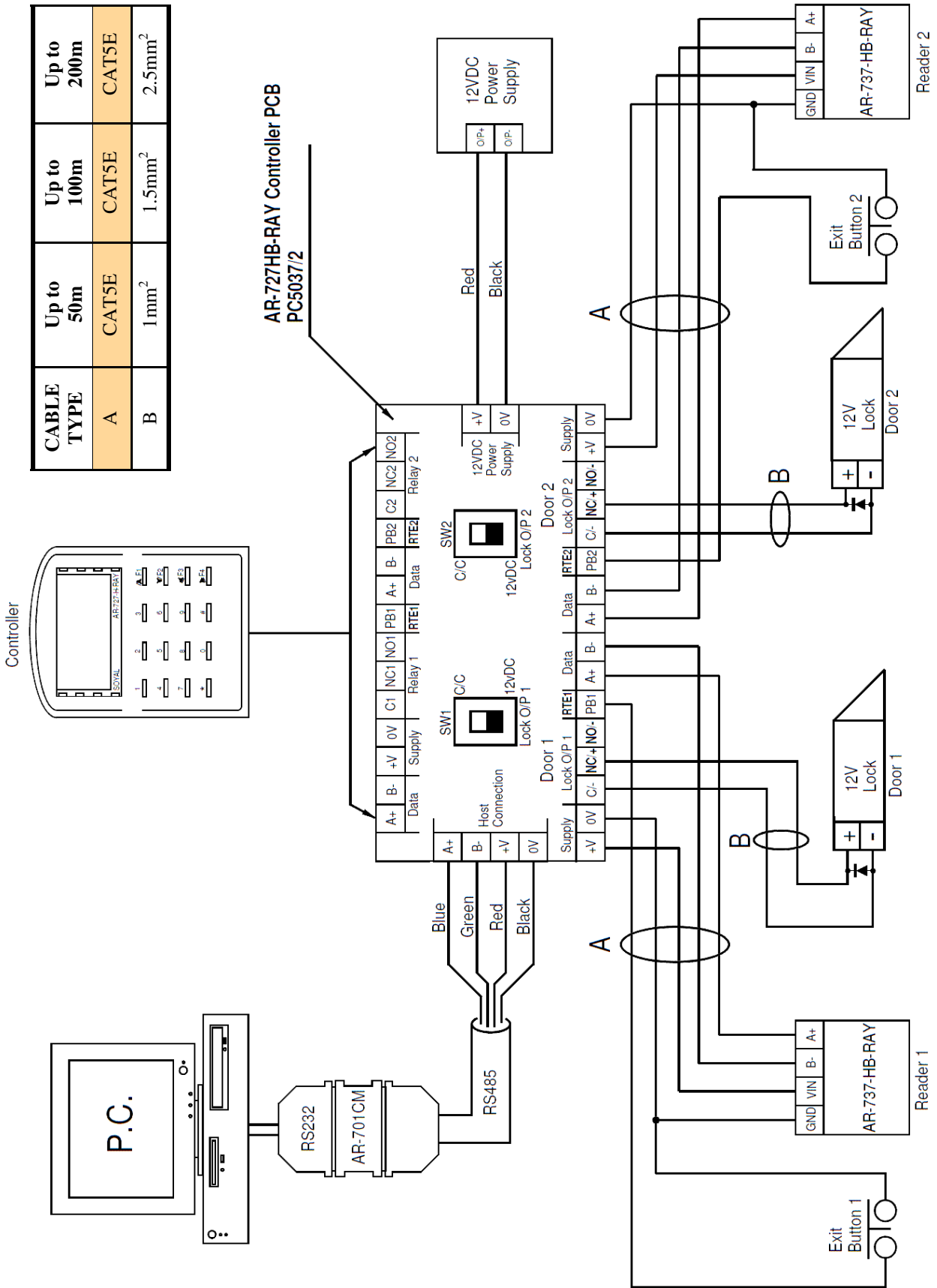

CABLE TYPE	Up to 50m	Up to 100m	Up to 200m
A	CAT5E	CAT5E	CAT5E
B	1mm ²	1.5mm ²	2.5mm ²

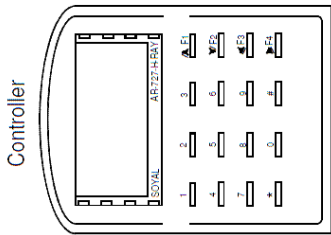

CONNECTIONS FOR CONTROLLER WITH TWO FAIL SECURE RELEASES

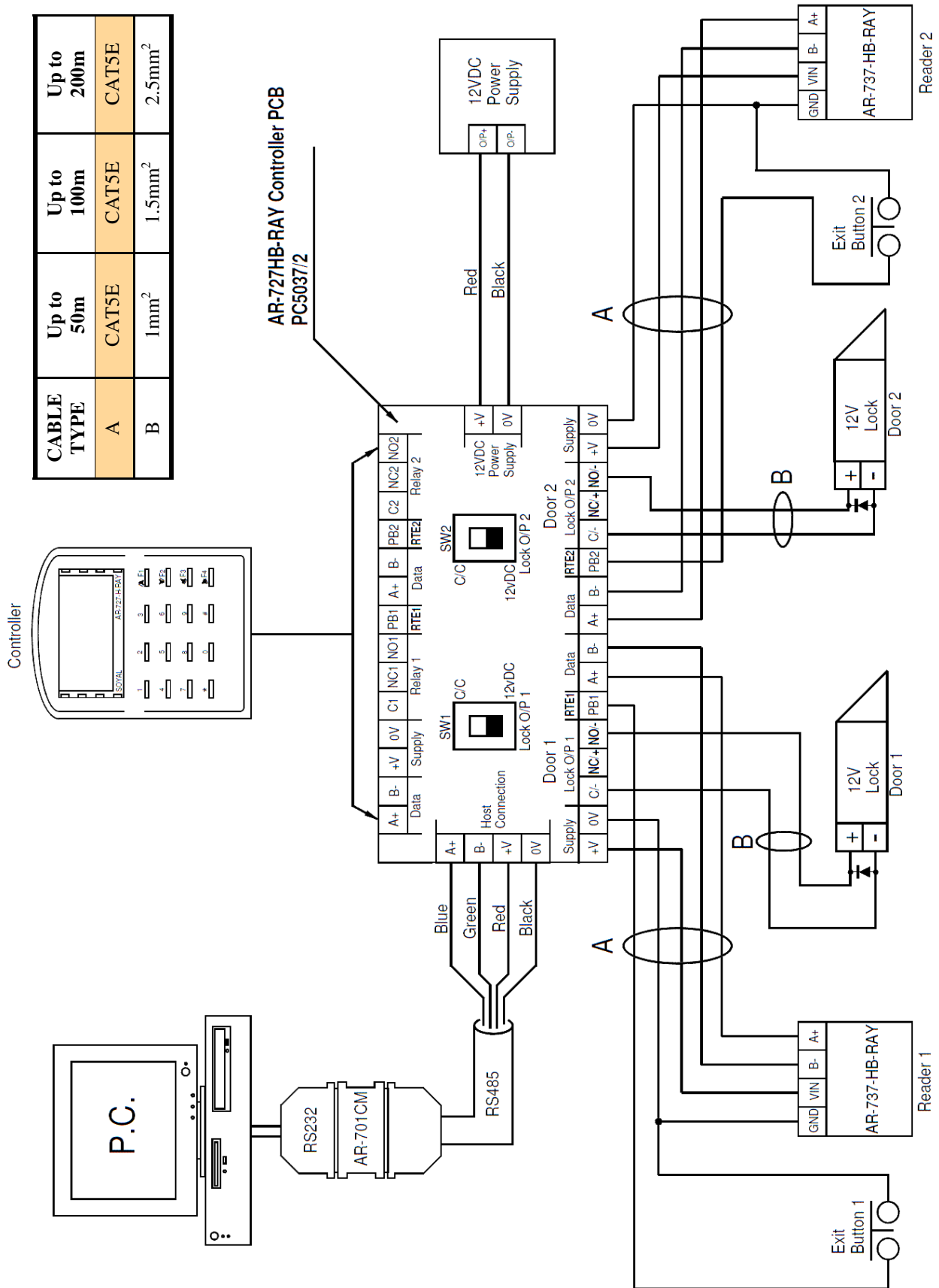

CABLE TYPE	Up to 50m	Up to 100m	Up to 200m
A	CAT5E	CAT5E	CAT5E
B	1mm ²	1.5mm ²	2.5mm ²

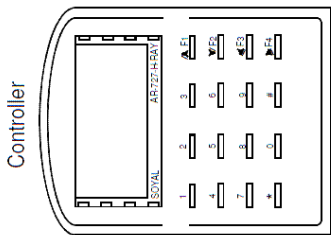

CONNECTIONS FOR CONTROLLER WITH CLEAN CONTACT OUTPUTS

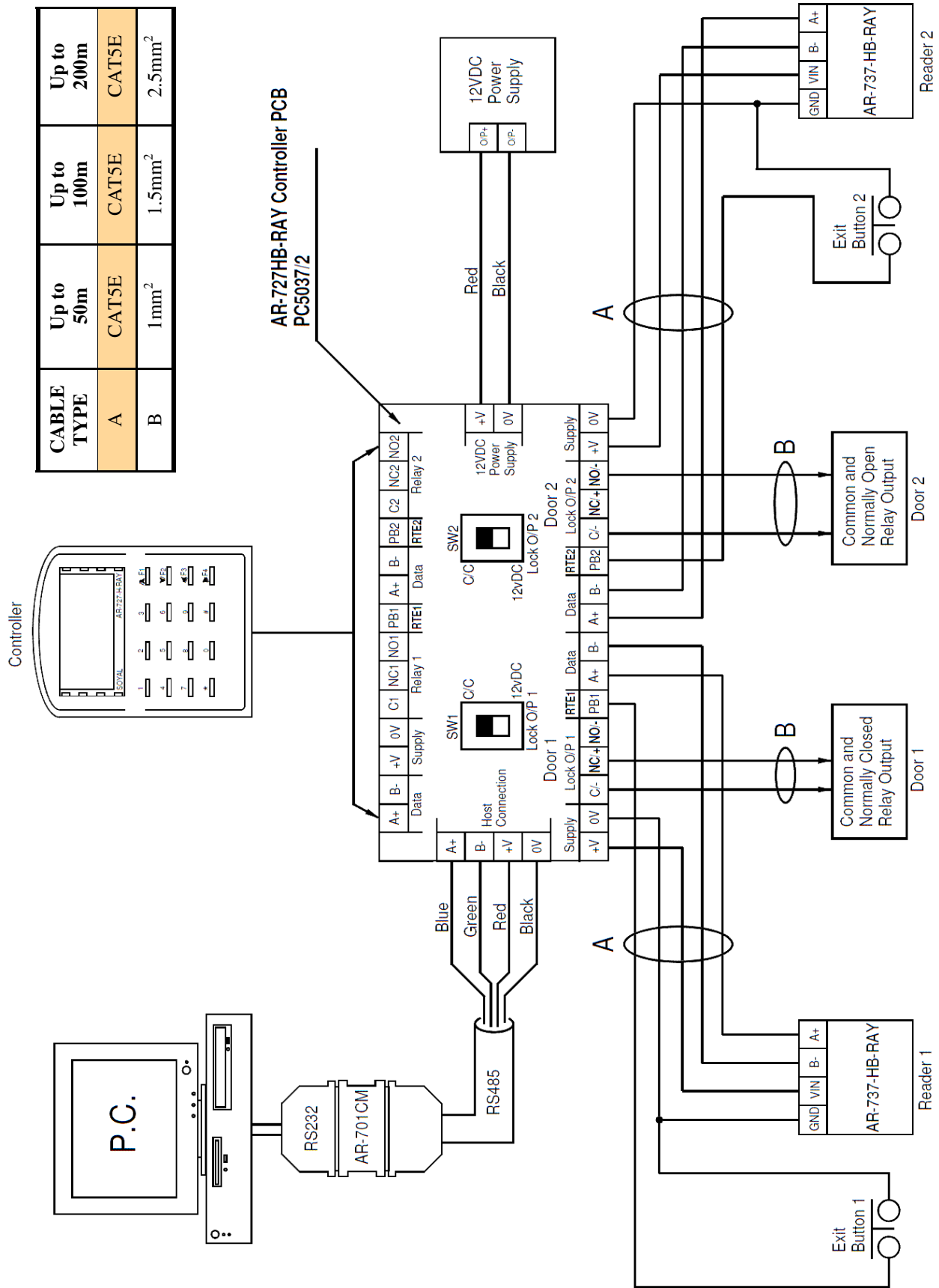

CABLE TYPE	Up to 50m	Up to 100m	Up to 200m
A	CAT5E	CAT5E	CAT5E
B	1mm ²	1.5mm ²	2.5mm ²

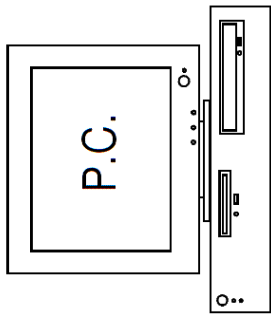
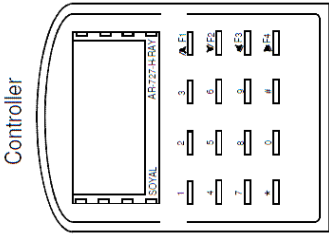

PROGRAMMING MENU TREE

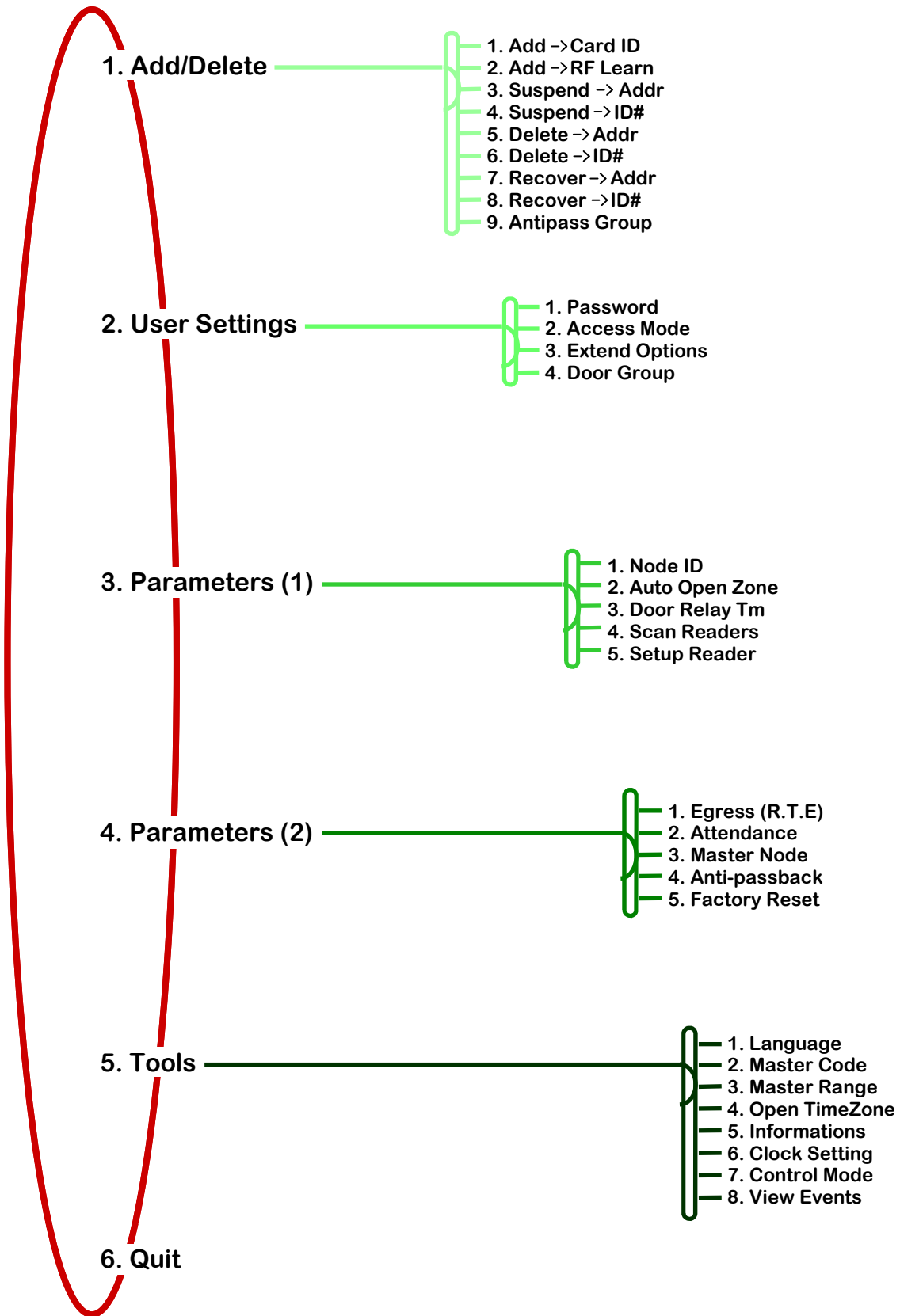

Enter programming mode by entering *Master Code#

Exit Programming mode by pressing * to step back through the menu until the display reads **6.Quit**, then enter # to confirm.

If no keys are pressed for 30 seconds, programming mode will time out and the unit will return to normal operation.

PROGRAMMING

Entering and Exiting Programming mode

In order to program any functions of the AR-727H-RAY Controller you must first access the programming mode by entering the factory master code. This is done by pressing the following buttons:

***123456#**

When the # button is pressed after the master code has been entered, the controller will enter into programming mode and the display will show:

1. ADD/DELETE

From here the programming can be carried out by following the relevant sections of this guide.

The Master Code can be changed, and it is recommended that system organisers do so for security reasons; however, if the new code is lost, the controller will need to have the master code reset to the factory master code by using the PC software.

To escape from programming press the * button to step back through the menu until the display reads 6. Quit, then press # to confirm. If no keys are pressed for several seconds, the unit will automatically return to standby.

INITIAL SETUP

Restoring Factory Settings

If for any reason, there is any uncertainty about what settings have been changed, it is possible to restore the factory default settings. It is always advisable to start by performing a factory reset before commencing any other programming. This will ensure that all settings are started from a known position.

To do so, follow this sequence:

***123456# OR *MASTER CODE#**

Use the **F1/up** or **F2/down** key to scroll to :

4. PARAMETERS (2)

Press # to enter this section

Use the **F1/up** or **F2/down** key to scroll to :

5. FACTORY RESET

Press # to enter this section

The display should now show:

SUCCEEDED!

The display should then briefly show:

INITIAL SYSTEM.

The factory default settings have now been restored..

EXTREMELY IMPORTANT MEMORY LOCATION INFORMATION

Before any tokens are added to an existing controller, the contents of the current memory locations should be checked and noted. This is to prevent any existing memory locations from being overwritten and data permanently lost.

To do this follow this sequence:

FACTORY MASTER CODE*123456# (OR *USER MASTER CODE# IF ALREADY CHANGED)

The screen should then show: **1. Add/Delete**

Use the or **F2 down** key to scroll to :

5. Tools

Press **#** to enter this section

Use the **F1/up** or **F2/down** key to scroll to :

5. Information

Press **#** to enter this section

The display should now show, for example:

727 7V1 125K

(PROD. NO., FIRMWARE VERSION., OPERATING FREQ.)

00008

(NUMBER OF MEMORY SLOTS OCCUPIED BY VALID TOKENS)

MESSAGES

00078

('Messages' indicates the number of times that tokens have been read by the readers).

In order to exit **Information**, press ***** to step back until you reach the main menu.

Note

The above information is used as an example only and other controllers will have different data, but the same format. If there are occupied memory slots, check in Add Card ID in Add/Delete by scrolling back to slot 00000 by using F3 and then scrolling forward with F4 to identify occupied slot numbers before entering new tokens. 00000:00000 indicates a vacant slot and any sequence of ten numbers indicates a valid token number.

Important Notice:-

The last page of this manual is a token/memory slot record sheet. The blank sheet should be photocopied and the photocopy kept up-to-date with the location and number of each token added or deleted. Failure to do so might result in valid tokens being overwritten when batches of tokens are added en bloc if deletion of individual tokens have left vacant memory slots scattered amongst valid tokens. If the first token in a new batch is directed to a single vacant memory slot, then the rest of the batch will overwrite (and replace) any subsequent valid tokens in the memory. For this reason, it is advisable to visit the Add Card > ID programme (see note above) before adding tokens since the F3 and F4 functions can be used to identify the location and quantity of vacant memory slots even if the Token Record Sheet has not been kept up-to-date. **This applies to all firmware versions up to and including 7V1. Version 7V2 automatically avoids overwriting valid tokens. A record should still be kept of token location in the memory, however, to facilitate deletion of specific tokens.**

PROGRAMMING

Changing the Master Code

It is recommended to change the master code from the default setting to keep the system secure.

To do so, follow this sequence:

***123456# (OR *MASTER CODE# IF
ALREADY CHANGED)**

Use the **F1/up** or **F2/down** key to scroll to :

5. TOOLS

Press **#** to enter this section

Use the **F1/up** or **F2/down** key to scroll to :

2. MASTER CODE

Press **#** to enter this section

The display should now show:

INPUT 6 DIGIT NO 000001~999999

Enter the new 6 digit master code

The display should now show:

SUCCEEDED!

The Master code should now be the 6 digit code that was just entered. **Please make a note of it and keep it safe.**

Turning off Time and Attendance

If the Time and Attendance functions are not being used, it is recommended that this function is turned off in order to avoid confusion with the controller display.

To do so, follow this sequence:

***123456# OR *MASTER CODE#**

Use the **F1/up** or **F2/down** key to scroll to :

4. PARAMETERS (2)

Press **#** to enter this section

Use the **F1/up** or **F2/down** key to scroll to :

2. ATTENDANCE

Press **#** to enter this section

The display should now show:

TIME ATTENDANCE 1:YES 2:NO

Press **2** for NO

The display should now show:

SUCCEEDED!

The Time and attendance function is now disabled.

Note:- This function was designed for one particular bespoke system and cannot be used on a general basis.

PROGRAMMING

Standby Mode:-

In the standby mode, the display will show the date and time followed by:- **Ready ...** . The display will always return to this format whenever programming is terminated, either by pressing **Quit** (number 6 in the main programming menu) or by the system automatically exiting the programming mode if none of the keys have been pressed for several seconds.

Setting the Time and Date :-

Enter * **Master Code #**

Use F2 to scroll down through main menu to:-

5. Tools

Press # to enter.

Use F2 to scroll down through Tools menu to:-

6. Clock Setting

Press # to enter.

The display should now indicate:-

Input date and time

YyMmDdHhMmSs

Enter two digits for year/month/day/hour/minutes/seconds.

The display should now indicate:-

Month/Day Format

1:DD/MM 2:MMDD

Current Data: 2

Enter **1** or **2** depending upon the order preferred and press #

The display should now indicate:-

Succeeded

Press * to step back through menu to **Quit**

PROGRAMMING

Setting up the Readers

(See page 4 for switch settings on the back of the readers. These settings are vital for correct RS485 function.)

All new readers are factory set to be Node 1. In a 2 door system with two readers, the second reader will have to be programmed to be Node 2.

To do so, first connect **only one** reader ie. the reader that is to be designated node 2, to the controller and follow this sequence:

***123456# (OR *MASTER CODE# IF ALREADY CHANGED)**

Use the **F1/up** or **F2/down** key to scroll to :

3. PARAMETERS(1)

Press **#** to enter this section

Use the **F1/up** or **F2/down** key to scroll to :

5. SETUP READER

Press **#** to enter this section

The display should now show:

**INPUT NEW NODE ID
RANGE 001~254**

Press **2.** to change this reader to node 2. The display should then change to:

TAG IN RF FIELD:

Press **1** for the reader to beep when shown a token or **0** for no beep when a token is shown.

The display should then change to:

THE LED: GREEN

Press **1** for the Green LED to illuminate when access is **granted** or **0** for the LED not to illuminate.

The Display should then change to:

THE LED: RED

Press **1** for the Red LED to illuminate when access is denied or **0** for the LED not to illuminate.

The display should now show:

SUCCEEDED!

The reader that is connected has now been changed to Node 2 and the LEDs and Beep have also been set..

Now a second reader that already has a default setting of node1, can be connected to the controller. Unless LED and Beep settings need to be changed, there should be no need to programme the Node 1 reader.

**IF UNCERTAIN ABOUT A READER'S ID
CONNECT ONE READER AT A TIME AND
PROGRAMME ONE AS NODE 1 AND THE
OTHER AS NODE 2. THEN CONNECT BOTH
READERS.**

PROGRAMMING

Scan Readers

Each controller scans the RS485 output to see if the readers are connected. If they are not connected it will show the reader as being disconnected on the PC software event log.

For this reason, each controller should be programmed with how many readers it has connected.

To do so, follow this sequence:

***123456# (OR *MASTER CODE# IF
ALREADY CHANGED)**

Use the **F1/up** or **F2/down** key to scroll to :

3. PARAMETERS (1)

Press **#** to enter this section

Use the **F1/up** or **F2/down** key to scroll to :

4. SCAN READERS

Press **#** to enter this section

The display should now show:

ONLINE READER 0:X

Press 1 for only 1 reader which is set as Node 1

Press 2 for only 1 reader which is set as Node 2

Or Press 3 if 2 readers are connected and they are set as Node 1 and 2 respectively.

The display should now show:

SUCCEEDED!

PROGRAMMING

STOP! ... SEE PAGE 11 FIRST

Adding a Single Token only using the Token ID

There are two ways a single token can be added, one method uses the controller's internal reader to add the token to the controller, the other method is to enter the token identification number into the controller.

To program a single token using the token ID follow this sequence:

***123456# OR *MASTER CODE#**

Use the **F1/up** or **F2/down** key to scroll to :

1. ADD/DELETE

Press **#** to enter this section

Use the **F1/up** or **F2/down** key to scroll to :

1. ADD->CARD ID

Press **#** to enter this section

The display should now show:

USER ADDRESS

If this is a new installation enter 0 and press #, otherwise use the next available memory location shown by pressing # without entering a number.

The display should now show:

SET 0000 SITE:

Enter the first 5 digits of the two part number shown on the token, see diagram below.

The display should now show:

SET 0000 CODE:

Enter the second 5 digits of the two part number shown on the token, see diagram below.

The display should now show:

SUCCEEDED!

The token has now been added to the system and can now be used on the reader that is connected.

A record of token numbers and memory locations should be kept by the system administrator to enable deletion of lost tokens (A blank Token Record Sheet can be found on the last page of this manual).

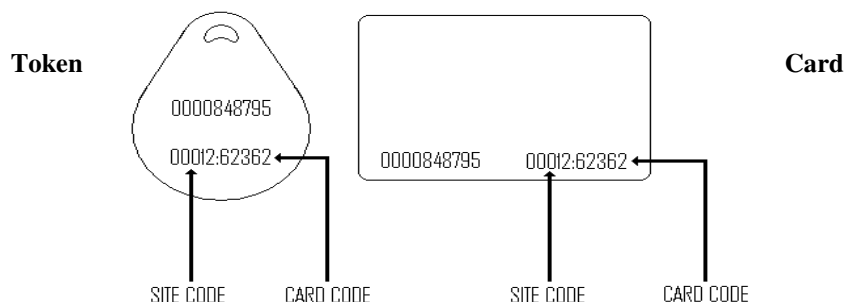

PROGRAMMING

STOP! ... SEE PAGE 11 FIRST

Adding a Single Token Using the RF Learn Function

There are two ways a single token can be added, one method uses the internal reader to learn the token to the controller, the other method is to enter the token identification number into the controller.

To program a single token using the token ID follow this sequence:

***123456# OR *MASTER CODE#**

Use the **F1/up** or **F2/down** key to scroll to :

1. ADD/DELETE

Press **#** to enter this section

Use the **F1/up** or **F2/down** key to scroll to :

2. ADD->RF LEARN

Press **#** to enter this section

The display should now show:

USER ADDRESS

If this is a new installation enter 00000 and press #, otherwise use the next available memory location shown by pressing # without entering a number.

The display should now show:

TAG UNITS (PCS)

Leave the suggested number as **00001** and press **#**

The display should now show:

CLOSE TAG INTO RF AREA

Present the token to the controller.

The display should now show:

(MEMORY LOCATION NUMBER) OK

The token has now been added to the system and can be used on the reader that is connected

A record of token numbers and memory locations should be kept by the system administrator to enable deletion of lost tokens (A blank Token Record Sheet can be found on the last page of this manual).

PROGRAMMING

STOP! ... SEE PAGE 11 FIRST TO AVOID OVERWRITING VALID TOKENS ALREADY IN SYSTEM MEMORY

Adding a Batch of Tokens Using the RF Learn Function (Sequential Token Numbers)

A batch of tokens can only be added by using the RF learn function.

To program a batch of tokens **with sequential numbers** follow this sequence:

***123456# OR *MASTER CODE#**

Use the **F1/up** or **F2/down** key to scroll to :

1. ADD/DELETE

Press **#** to enter this section

Use the **F1/up** or **F2/down** key to scroll to :

2. ADD->RF LEARN

Press **#** to enter this section

The display should now show:

USER ADDRESS

If this is a new installation enter 00000 and press #, otherwise check in 'Add/ID for the next available block of consecutive empty memory locations for the number of tokens being entered, note the first slot in that block and return to Add RF Learn and User Address and select the first empty memory slot in the block and press # without entering a number.

The display should now show:

TAG UNITS (PCS)

Enter the **quantity of tokens** to be added and press **#**

The display should now show:

CLOSE TAG INTO RF AREA

Present the token with the **lowest number** to the controller.

The display should now show:

(MEMORY LOCATION NUMBER) OK

The whole batch of tokens will now have been added to the system and can now be used on the reader that is connected.

A record of token numbers and memory locations should be kept by the system administrator to enable deletion of lost tokens (A blank Token Record Sheet can be found on the last page of this manual).

PROGRAMMING

STOP! ... SEE PAGE 11 FIRST

Adding a Batch of non-sequential Tokens Using the RF Learn Function (Random Token Numbers)

A batch of tokens can only be added by using the RF learn function.

To program a batch of tokens **with random numbers** follow this sequence:

***123456# OR *MASTER CODE#**

Use the **F1/up** or **F2/down** key to scroll to :

1. ADD/DELETE

Press **#** to enter this section

Use the **F1/up** or **F2/down** key to scroll to :

2. ADD->RF LEARN

Press **#** to enter this section

The display should now show:

USER ADDRESS

If this is a new installation enter 00000 and press #, otherwise check in 'Add/ID for the next available block of consecutive empty memory locations for the number of tokens being entered, note the first slot in that block and return to Add RF Learn and User Address and select the first empty memory slot in the block and press # without entering a number.

The display should now show:

TAG UNITS (NO. OF PCS)

Press 1 and # together

The display should now show:

CLOSE TAG INTO RF AREA

Present a Token to the controller.

The display should now show:

(MEMORY LOCATION NUMBER) OK

The First token has now been added, present the rest of the tokens one after the other to add them to the system as well.

A record of token numbers and memory locations should be kept by the system administrator to enable deletion of lost tokens (A blank Token Record Sheet can be found on the last page of this manual).

PROGRAMMING

STOP! ... SEE PAGE 11 FIRST

Deleting a Single Token Using the Token ID

Deleting a single token can be done by two methods, one method using the token ID number and the other method by using the memory location. Remember that if a Lost token is to be deleted, the Record of token ID's and their memory location, that should have been made when the tokens were added will be required.

To Delete a single token using the Token ID follow this sequence:

***123456# OR *MASTER CODE#**

Use the **F1/up** or **F2/down** key to scroll to :

1. ADD/DELETE

Press **#** to enter this section

Use the **F1/up** or **F2/down** key to scroll to :

6. DELETE->ID

Press **#** to enter this section

The display should now show:

SET SITE:

Enter the first 5 digits of the two part number shown on the token, see diagram below, or from the token record sheet.

The display should now show:

SET CODE:

Enter the second 5 digits of the two part number shown on the token, see diagram below, or from the token record sheet

The display should now show:

SUCCEEDED!

The Token has now been removed from the system.

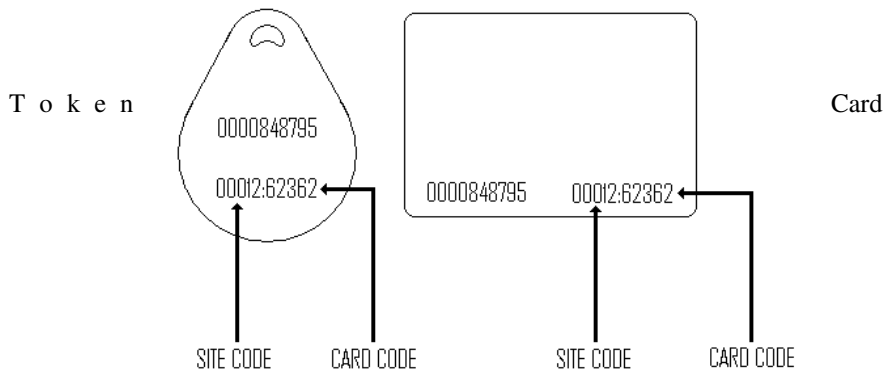

PROGRAMMING

STOP! ... SEE PAGE 11 FIRST

Deleting a Single Token Using the Memory Location

Deleting a single token can be done by two methods, one method using the token ID number and the other method by using the memory location. Remember that if a Lost token is to be deleted, the Record of token ID's and their memory location, that should have been made when the tokens were added will be required.

To Delete a single token using the Memory Location follow this sequence:

***123456# OR *MASTER CODE#**

Use the **F1/up** or **F2/down** key to scroll to :

1. ADD/DELETE

Press **#** to enter this section

Use the **F1/up** or **F2/down** key to scroll to :

5. DELETE->ADDR

Press **#** to enter this section

The display should now show:

INPUT START ADDR:

Enter the memory location number that has been stored on the token record sheet for the token that needs to be deleted.

The display should now show:

INPUT END ADDR:

Enter the same memory location number that has been stored on the token record sheet for the token that needs to be deleted, as before

The display should now show:

SUCCEEDED!

The Token has now been removed from the system.

PROGRAMMING

STOP! ... SEE PAGE 11 FIRST

Deleting a Batch of Token Using the Memory Location

Deleting a batch of tokens can only be achieved by using the memory location. Remember that if a Lost token is to be deleted, the Record of token ID's and their memory location, that should have been completed when the tokens were added ,will be required.

To Delete a batch of tokens using the Memory Location follow this sequence:

***123456# OR *MASTER CODE#**

Use the **F1/up** or **F2/down** key to scroll to :

1. ADD/DELETE

Press **#** to enter this section

Use the **F1/up** or **F2/down** key to scroll to :

5. DELETE->ADDR

Press **#** to enter this section

The display should now show:

INPUT START ADDR:

Enter the memory location number that has been stored on the token record sheet for the token in the first memory location that needs to be deleted.

The display should now show:

INPUT END ADDR:

Enter the final memory location number that has been stored on the token record sheet for the token that needs to be deleted, as before

The display should now show:

SUCCEEDED!

The Batch of Token in the range of memory addresses entered have now been removed from the system.

PROGRAMMING

Adjusting the Lock Activation Time

The time duration that the lock relay is active for can be adjusted between 0 and 600 seconds.

To change the relay activation duration follow this sequence:

***123456# OR *MASTER CODE#**

Use the **F1/up** or **F2/down** key to scroll to :

3. PARAMETERS (1)

Press **#** to enter this section

Use the **F1/up** or **F2/down** key to scroll to :

3. DOOR RELAY TM

Press **#** to enter this section

The display should now show:

INPUT: (0~600)
RELAY 0
CURRENT DATA 002

Enter the activation time required for relay 0 in seconds

The display should now show:

INPUT: (0~600)
RELAY 1
CURRENT DATA 002

Enter the activation time required for relay 1 in seconds

The display should now show:

SUCCEEDED!

The Lock relay should now operate for the time that has just been programmed.

PROGRAMMING

Setting Latch Mode

When Latch Mode has been set, the lock relay will switch and the door will latch open after a valid programmed token/card has been presented.
The door will then stay open until a valid programmed token/card is presented and then the relay will switch back and the door will lock.

To set Latch Mode follow this sequence:

***123456# OR *MASTER CODE#**

Use the **F1/up** or **F2/down** key to scroll to :

3. PARAMETERS (1)

Press **#** to enter this section

Use the **F1/up** or **F2/down** key to scroll to :

3. DOOR RELAY TM

Press **#** to enter this section

The display should now show:

INPUT: (0~600)
RELAY 0
CURRENT DATA 002

Enter **0** if Latch Mode is required, if not enter required lock activation time in seconds.
The display should now show:

INPUT: (0~600)
RELAY 1
CURRENT DATA 002

Enter **0** if Latch Mode is required, if not enter required lock activation time in seconds.
The display should now show:

SUCCEEDED!

Lock relays should now latch open when a valid programmed token/card is presented. To lock the doors, present a valid programmed token/card.

PROGRAMMING

Enabling and Setting Automatic Door Opening Times.

Enter * Master Code #

The display should now show:-

1. Add/ Delete

Using F2, scroll down to:-

3. Parameters (1)

Press # to enter.

Using F2, scroll down to:-

2. Auto Open Zone

Press # to enter

The display should now show:-

Auto Open Zone

1: YES 2: NO

Data: 2

Press 1 for **YES** to enable the automatic door opening Programme.

The display should now show:-

Succeeded.

To set the dates and times, press* to return to the main menu.

Using F2, scroll down to:-

5. Tools

Press # to enter

Using F2, scroll down to:-

4. Open Time Zone

Press # to enter

The display should now show:-

Select Set Num:

1:00:00 - 00:00

2:00:00– 00:00

Enter **1** for time zone 1 and **2** for time zone 2.

Continued on page 26

PROGRAMMING

Enabling and Setting Automatic Door Opening Times (continued).

Assuming that time zone 1 has been selected,
the display should now show:-

Available Weekday
Sun—Mon—...—Sat
Cur.—>1: 0000000

This means that times can be set from Sunday to Saturday. The current time zone is **1**. The seven zeros indicate that this time zone is not active on any of the seven days of the week, commencing with Sunday. To change this, enter a row of seven numbers with **0** indicating no active time zone and **1** indicating that an active time zone is required on that day. For example, **0111110** would mean that automatic door opening was required from Monday to Friday but not on Sunday or Saturday. After the seven numbers have been entered, the display should show:-

Start-Stop Time
Ex: 08001230 (example)
Cur. - > 1: 00000000

Enter eight numbers representing the start and stop times as shown in the example above.

The display should now show:-

Succeeded

If a second time zone is required, press **#** to re-enter the programme and repeat the process for time zone 2.

Anti-Passback

Enabling Anti-Passback

Enter * **Master Code #** to enter the programming mode.
Use **F2** to scroll to **7. Anti-passback** and press **#** to enter.
The display will show:-

Enable Antipass
1: Yes 2: No
Data : 2

(Data indicates the current setting).

Enter 1 to enable Anti-Passback

The display will now show:-

In or Out Door
1: In 2: Out
Data : 2

Enter the number required.

The display will now show:-

Succeeded!

Now that the anti-passback function has been enabled, it is necessary to enter either the individual cards/tokens to which this function applies or the group of cards/tokens to which it applies.

Applying anti-passback to Individual Cards/Tokens

Enter * **Master Code #** to enter the programming mode.
Use **F2** to scroll to **2. User Settings** and press **#** to enter.
Use **F2** to scroll to **3. Extend Options** and press **#** to enter
The display will show:-

User Address :
F3: Prev F4: Next
(0-01023): 00000

Enter the user address (Memory Slot in which the token has already been entered). The controller's

Continued on page 28

Anti-passback continued

memory is, in effect 'circular' since the memory slot after 01023(the last memory slot) is 00000 (the first memory slot). So that it is possible to move continuously around the memory by using F3 and F4. After entering the appropriate user address, **Press #**.

The display will now show:-

Succeeded!

Applying Anti-passback to a block of Cards/Tokens

Enter * **Master Code #** to enter programming mode.

The display should now show :-

1. Add/Delete

Press **#** to enter.

Use **F2** to scroll down to **9. Antipass Group** and press **#**.

The display will show:-

Input Start Addr
(0-01023) : 01023

Enter the first user address (memory slot) and press **#**

The display will now show:-

Input End Addr
(-01023) : 00001

Enter the last user address and press **#**

The display will now show:-

Enable Antipass
1: Yes 2: No
Data : 1

Enter the number required.

The display will show:-

Succeeded!

Please note:- The anti-passback function will only be activated if the enabling procedure at the beginning of this section has been carried out.

AR-727HB-RAY RESETTING MASTER CODE

Resetting Master Code

If for any reason the master code needs resetting, you will need to exit 701 Server first. Right click on the 701 server icon  in the bottom right of the toolbar and click exit.

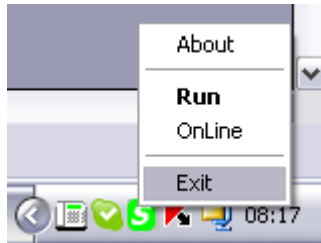

Connect the controller to the PC using an AR-701CM RS-232/RS-485 Converter or an AR-321CM USB/RS-485 Converter.



Open ISP Tools and select RAY727H from the list on the left hand side, then select the relevant COM Port and Node Number of the controller.

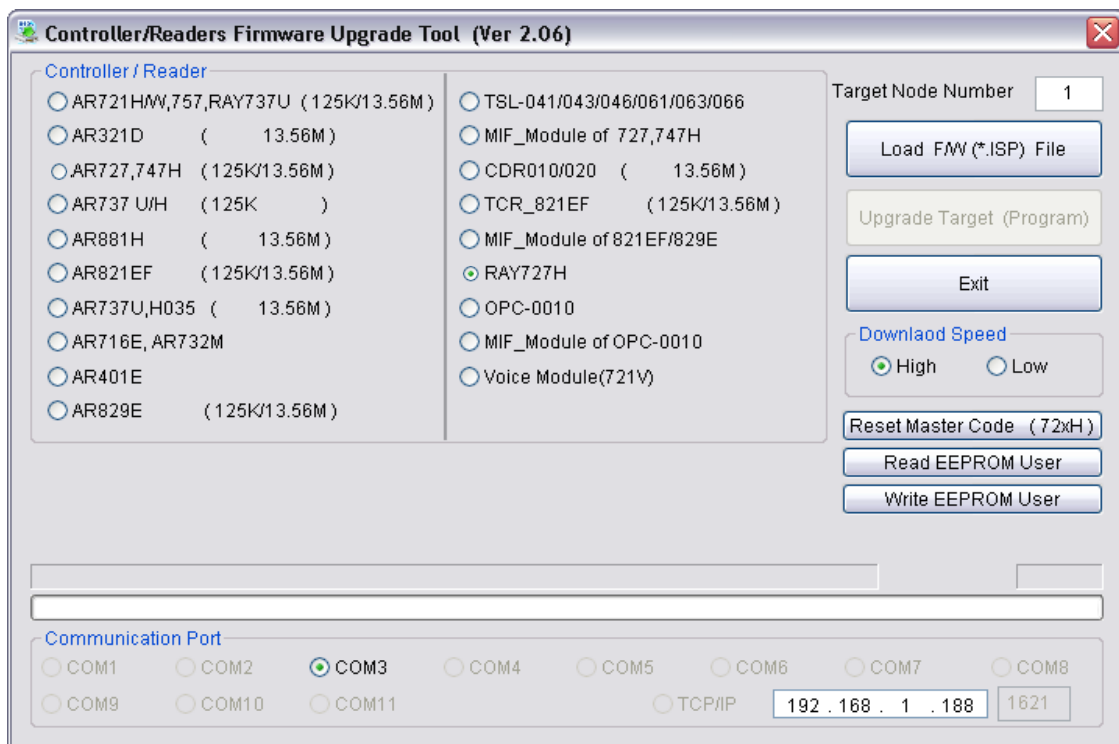

Click on the Reset Master Code button  and the master code will be reset to *123456#.

AR-727HB-RAY UPGRADING FIRMWARE

Upgrading Firmware

If for any reason the firmware needs upgrading, you will need to exit 701 Server first. Right click on the 701 server icon  in the bottom right of the toolbar and click exit.

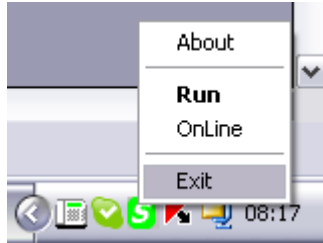

Connect the controller to the PC using an AR-701CM RS-232/RS-485 Converter or an AR-321CM USB/RS-485 Converter.



Open ISP Tools and select RAY727H from the list on the left hand side, then select the relevant COM Port and Node Number of the controller.

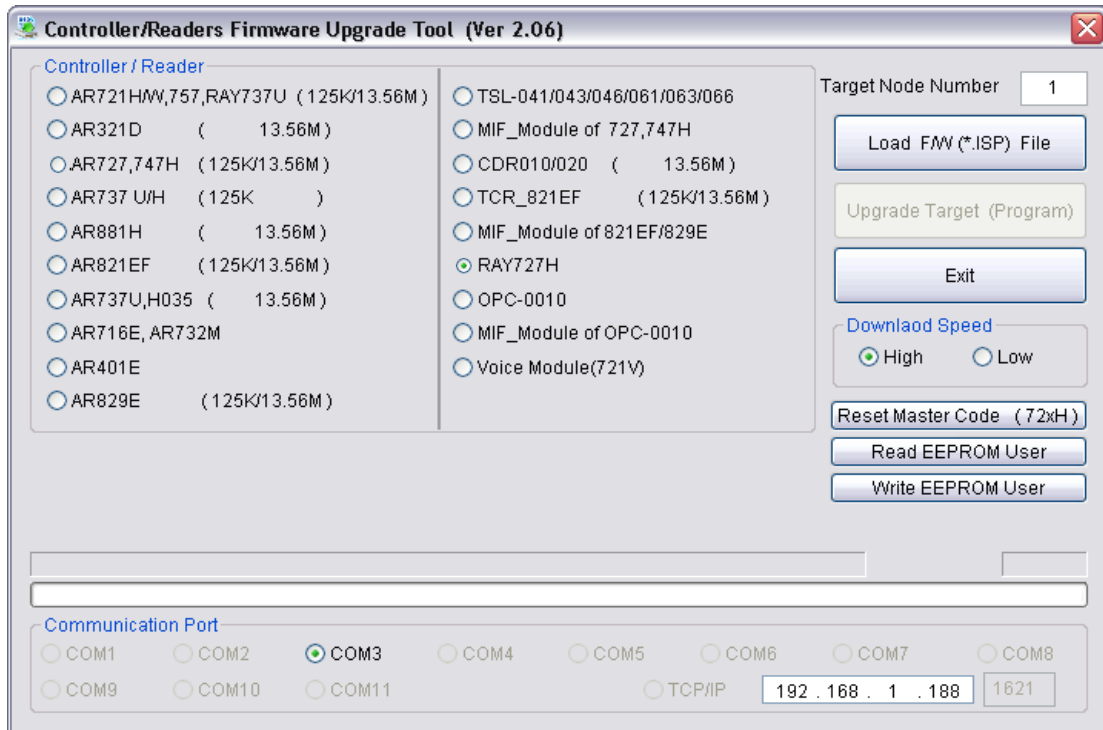

Click on the Load F/W button  and select the version of firmware you want to upgrade to.

Then click on the Upgrade Target button. 

This Quick Guide is intended to help installers to set up and operate the AR727HB-RAY Proximity Access Controller in Standalone mode. This controller is, however, capable of fulfilling many more complex functions.

For information regarding networking a number of controllers to a PC or for other applications such as Lift Control, please consult the appropriate manuals or contact our Technical

Department on 01268 749311 or either our Northern Sales Office on 0141 332 4232 or our Southern Sales Office on 01268 749312. Training is also available on request.